

- NOTES:
1. THE BOAT WALKING DECK CAN BE COVERED WITH EITHER .190 ALUMINUM PLATE OR PLYWOOD AT BUILDERS OPTION.
 2. AFTER WELDING, CUT DRAIN HOLES THROUGH THE TRANSOM TO ALLOW DRAINAGE OF THE MOTOR WELL.
 3. TRIM EXCESS OFF OF SIDE SHELL AFT END AFTER BOAT IS WELDED.

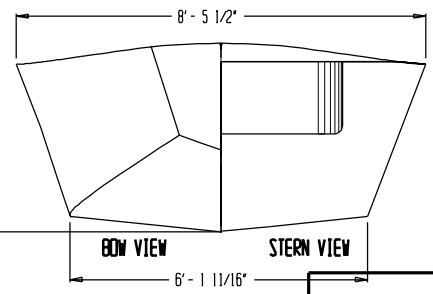
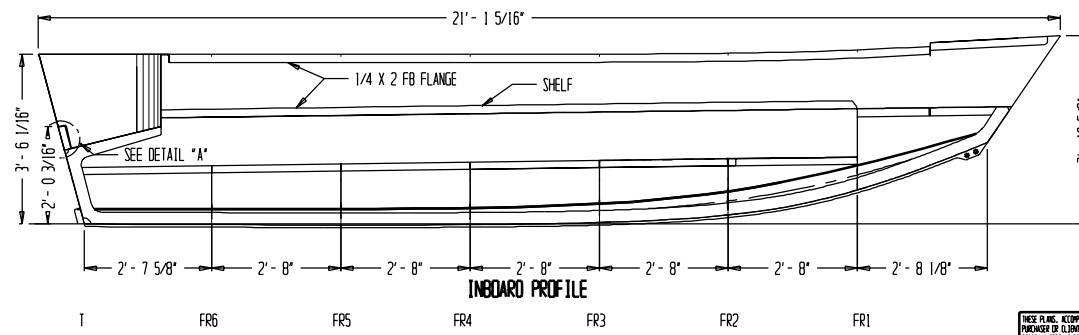
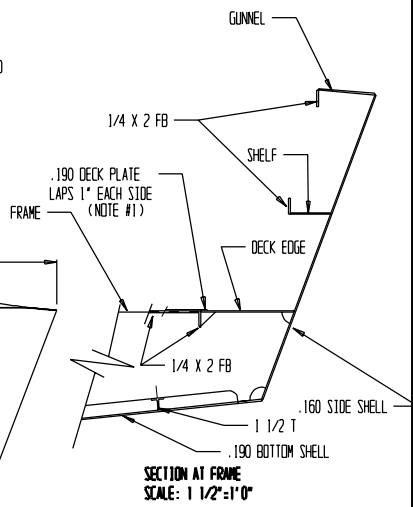

THESE PLANS, ACCOMPANYING INSTRUCTIONS, AND/OR SPECIFICATIONS, GRANT THE PURCHASER OR BUILDER OF RECORD RIGHTS TO BUILD THE BOAT THEREFROM. ALL DESIGN MATERIALS REMAIN THE PROPERTY OF THE DESIGNER AND ARE NOT TO BE REPRODUCED OR COPIED, IN WHOLE OR IN PART, WITHOUT THE WRITTEN PERMISSION OF THE DESIGNER. THESE MATERIALS ARE NOT TO BE USED FOR CONSTRUCTION UNLESS THE PURCHASER OR BUILDER OF RECORD HAS OBTAINED THE NECESSARY PERMISSION FROM THE DESIGNER.

SPECIALTY MARINE
 P.O. Box 1081, Seabrook, TX 77586
 21' OUTBACK COPYRIGHT
 SIZE: ESDH NO. DWG NO. 406SALES.PRT REV
 SCALE: 3/4"=1'-0" SHEET