

PLAN

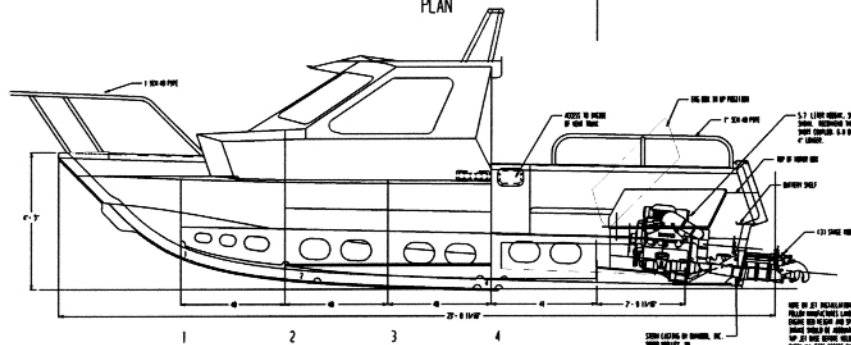

OUTBOARD PROFILE

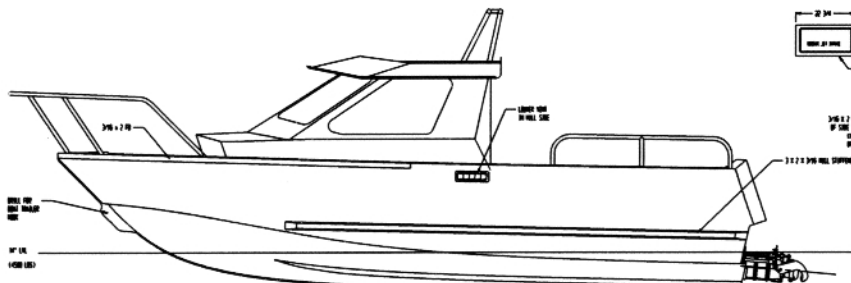

VIEW FROM BOW
LKG AFT

VIEW FROM STERN,
LKG FWD

SHAFTS EXPOSED FOR
REPAIR PURPOSES
(FRAMES IN THE SHELL AFTER THE SHELL
IS REPAIRED IN PLACE)

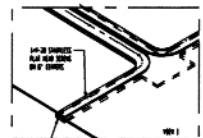

VIEW 1

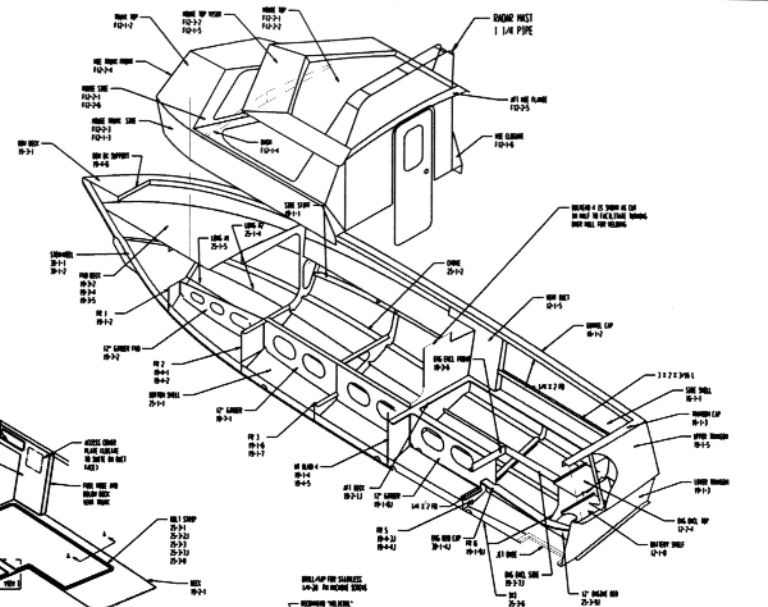

THIS PLAN, INCLUDING DIMENSIONS, AND ANY OTHER INFORMATION THEREON IS THE PROPERTY OF SPECIALTY MARINE. NO PART OF THIS PLAN OR ANY INFORMATION THEREON IS TO BE REPRODUCED, COPIED, OR TRANSMITTED IN ANY FORM OR BY ANY MEANS, WITHOUT THE WRITTEN PERMISSION OF SPECIALTY MARINE. SPECIALTY MARINE ASSUMES NO LIABILITY FOR ANY DAMAGE OR LOSS OF PROPERTY ARISING FROM THE USE OF THIS PLAN.

- NOTES:
1. WELD BOTTOM LONGS TO BOTTOM SHELL CONTINUOUS ON ONE SIDE. INTERMITTENT ON OTHER SIDE FROM FRAME 4 FORWARD. #1 OF FRAME 4. USE 2" INTERMITTENT WELDS ON 10" CENTERS. ALL OTHER INTERIOR FRAMING WELDS TO BE 2" INTERMITTENT WELDS, STAGGERED, ON 10" CENTERS.
 2. 3/16 X 1/2 FB FLANGES ON FRAMES 1, 2, AND 3 ARE TO ALLOW ATTACHMENT OF 3/4" FL WOOD THROUGH DECK.
 3. PROVIDE HAND ACCESS HOLES IN AFT DECK SIMILAR TO DECKSON DECK PLATES.
 4. REMOVE FUEL, FILL HOSE AND VENT UP VENT DECK. VENT MUST BE MINIMUM OF 12" FROM AIR INTAKE DECK.

5/13/04

SPECIALTY MARINE PO Box 1081, Schwanau, OR 97258			
23 SPORTFISHER PROFILE AND ARRANGEMENT			
SIZE	FRON NO.	ENG. NO.	REV.
SCALE 1/2"=1'-0"		920 VIEWS	
SHEET			1